

RMO-G series

Micro Ohmmeters

- Lightweight – from 8 to 11,5 kg/17.6 lbs to 25.4 lbs
- Powerful – up to 800 A DC
- Measuring range 0 – 999,9 mΩ (up to 6 Ω)
- Resolution 0,1 μΩ
- Typical accuracy ± (0,1 % rdg + 0,1 % FS)
- Remote Control Unit (optional)
- Both Sides Grounded Unit (optional)
- A built-in High Precision module (optional)
- *SINGLE / CONTIN / BSG / DTRtest* modes



Description

RMO-G series of Micro Ohmmeters (hereafter referred to as “RMO-G”) contain 7 models: **RMO100G, RMO200G, RMO300G, RMO400G, RMO500G, RMO600G and RMO800G.**

All RMO-G models are based on a state of the art technology, using the most advanced switch mode technique available today. The main difference between these models is the maximum test current that can be generated (100 A for RMO100G, 200 A for RMO200G, up to 800 A for RMO800G model).

RMO-G generates a true DC ripple-free current with automatically regulated test ramps. During a test the RMO-G ramps with increasing current before measuring and decreasing current after the measurement. This eliminates magnetic transients.

The RMO-G instrument can store internally up to 500 measurements. All measurements are time and date stamped. Using the DV-Win software a test can be performed from a PC and the results can be obtained directly on the PC.

Communication between the RMO-G and a PC is through an USB (as standard) or an RS232 cable (as an option). Using the DV-Win the result can be arranged as an Excel spreadsheet which can be later shown as a diagram and printed for a report.

The set is equipped with a thermal and an overcurrent protection. The RMO-G has a very high ability to cancel electrostatic and electromagnetic interference in HV electric fields. It is achieved by very efficient filtration. The filtration is made utilizing a proprietary hardware and software.

The RMO-G instrument has four separate test modes:

- SINGLE mode
- CONTIN mode
- BSG mode (*Both Sides Grounded*)
- DTRtest mode (*Dead Tank Resistance*)

Single Test

The RMO-G instrument generates a filtered (true ripple-free) DC current and output it in an automatically regulated current ramp. By sloping the current up and down, magnetic transients are virtually eliminated.

Below is an example of single test ramp for the 100 A current.

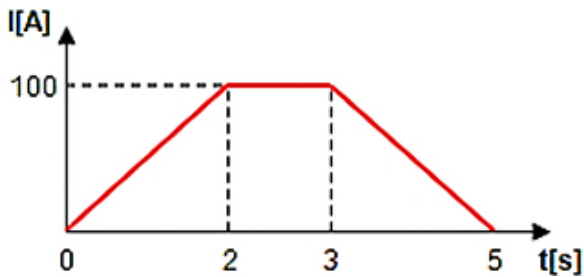

Continuous Test

RMO-G can generate DC current continuously in predefined test durations, as presented in the table below.

Test current (A)	Maximum test duration time (sec)
5, 10, 20, 50, 100	*300
200	150
300	90
400	50
500	30
600	20
800	**5

**test duration at 100 A test current can be up to 30 minutes as per request*

***in standard version CONTIN mode is available up to 600 A, but it can be available for 800 A (5 s) as per request*

To prevent overheating, certain duty cycles apply depending on the test current being used.

BSG test

Grounding circuit breakers from both sides provides increased safety for testing personnel comparing with only one side grounding method.

This test mode is specially designed for **Both Sides Grounded** testing. A special current clamp meter supplied from the instrument is used for measuring the current through the groundings. The test setup is very simple (same as for the SINGLE test) and all calculations are made automatically by the device internal algorithm.

DTRtest

Presence of current transformers (CT) on the dead tank circuit breakers may introduce errors during contact resistance measurement due to CT magnetizing process. For this reason, it is necessary to saturate a CT prior to measurement.

DTRtest menu is specially designed for resistance measurement of the dead tank circuit breakers. All calculations for detecting the saturated condition of CTs are done by internal algorithm. Accordingly, the process of measurement parameters setting and testing in this mode is very simple and does not differ much from live tank circuit breaker testing (in SINGLE / CONTIN test modes).

High – Precision module (optional)

The high-precision module is newly developed optional built-in addition to our RMO-G micro ohmmeters. It provides an increased precision and offers a highly accurate contact resistance measurement in the range from 1 $\mu\Omega$ to 30 $\mu\Omega$, with 0,01 $\mu\Omega$ resolution.

RMO-G devices with the built-in High Precision Module may be used for applications on very small resistance measurements of non-inductive test objects. This requirement is usually met at resistance inspections of generator circuit breakers, welding joints, GIS testing, etc.

Application

Typical application is measuring resistance of non-inductive test objects:

- High, middle and low voltage circuit breakers (live and dead tank)
- High, middle and low voltage disconnecting switches
- Gas Isolated Switchgears (GIS)
- High-current bus bar joints
- Cable splices
- Welding joints
- Fuses

Connecting the Test Object to RMO-G

The connection diagram of the RMO-G devices corresponds to the Kelvin's (four point) measurement principle. The measuring cables from the "Voltage Sense" sockets are attached as close as possible to Rx, and in between the current feeding cables. That way, a resistance of both cables and clamps is almost completely excluded from the resistance measurement.



The connecting diagrams for the live tank and dead tank circuit breakers are presented in the following two figures:

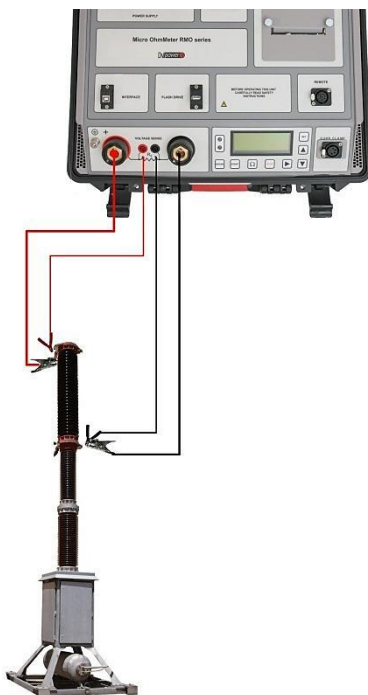

RMO-G cable connection on live tank circuit breaker

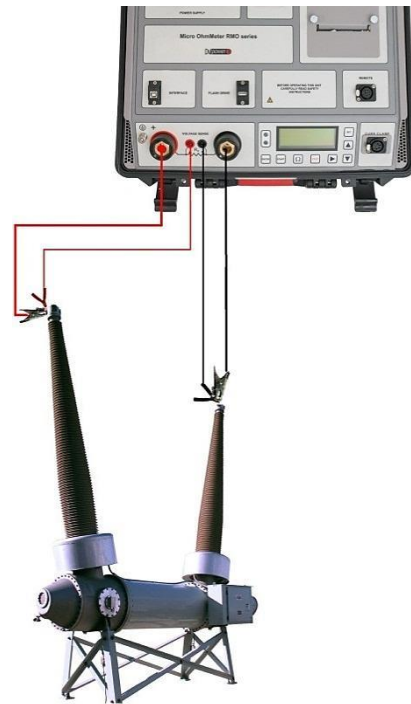

RMO-G cable connection on dead tank circuit breaker

Remote Control Unit

The RMO Remote Control Unit is an optional control unit that is used to start and stop the tests from a remote location, away from the actual RMO-G.

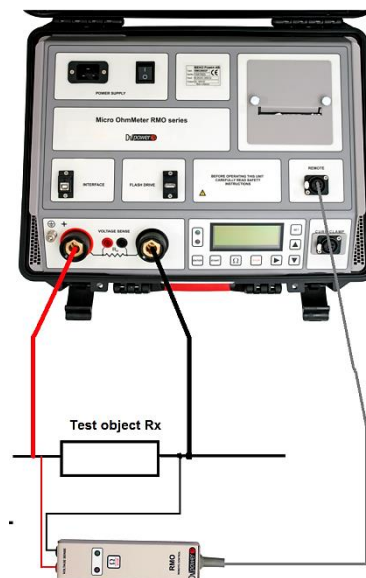

Provided that, for a series of tests, the same test current is fed through the test object, multiple measurements can be carried out with the RMO Remote Control Unit.

Connecting RMO-G to a Both Sides Grounded Circuit Breaker

Using RMO-G with both sides grounded option it is possible to make safer measurement of breakers with both terminals of the breaker grounded.

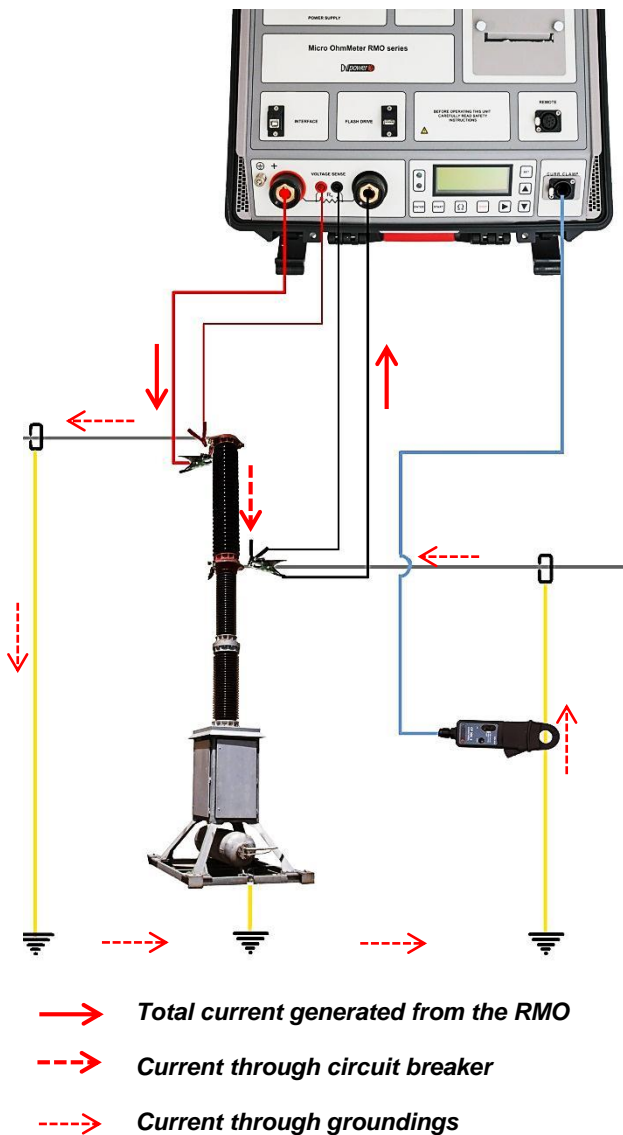

Using the RMO-G with a current clamp-meter is an additional safety feature. Measurement of a circuit breaker contact resistance is done with both sides of the breaker grounded. The RMO-G device will measure the current through the ground circuit connection and add this value to the selected test current value in order to provide the selected test current through the test object.

Benefits and features

The main benefits and features of RMO-G devices are listed below:

- Very high output power (output voltage multiplied with output current) enables two main advantages:
 1. Wide resistance measurement range even when very high currents are used.
e.g. RMO600G can test up to 5,3 mΩ with 600 A test current when 5 m / 50 mm² current cables are used.
 2. Use of thinner/longer test cables, depending of the customer requirement.
e.g. RMO100G can use 20 m current cables with cross-section of only 16 mm² for testing circuit breakers with 100 A test current.
- The output current is filtered and has a ripple of less than 1 %.
- The instrument has a very high typical accuracy $\pm (0,1 \% \text{ rdg} + 0,1 \% \text{ FS})$.
- The best resolution of RMO-G is 0,1 $\mu\Omega$.

Several advanced features are available as standard/optional accessories:

- Rmax feature – pass/fail criteria
- Built-in thermal printer (*optional*)
- USB or RS232 communication port
- Bluetooth communication (*optional*)
- DTRtest mode – a special mode for Dead Tank circuit breakers testing
- A built-in High Precision module (available as option) – provides an increased precision and offers a highly accurate contact resistance measurement in the range from 1 $\mu\Omega$ to 30 $\mu\Omega$, with 0,01 $\mu\Omega$ resolution.

Technical data

Mains power supply

- Connection according to IEC/EN60320-1; C320
- Mains supply: 90 V – 264 V AC
- Frequency: 50 / 60 Hz
- Power consumption

Model	@ 230 V AC	@ 115 V AC
RMO100G	1190 VA	1130 VA
RMO200G	1815 VA	1810 VA
RMO300G	2400 VA	2115 VA
RMO400G	3570 VA	2710 VA
RMO500G	3970 VA	3920 VA
RMO600G	4720 VA	4145 VA
RMO800G	5010 VA	3510 VA

- Fuse: *type F*
- | | |
|-------------------|--------------|
| RMO100G & RMO200G | 12 A / 230 V |
| RMO300G & RMO400G | 15 A / 230 V |
| RMO500G & RMO600G | 20 A / 250 V |
| RMO800G | 20 A / 250 V |

Output data

- Test current ranges and load intervals:

Model	Test current	Test duration
RMO100G	100 A	*300 s
RMO200G	200 A	150 s
RMO300G	300 A	60 s
RMO400G	400 A	60 s @300 A
RMO500G	500 A	30 s
RMO600G	600 A	20 s
RMO800G	800 A	**5 s

*test duration at 100 A test current can be up to 30 minutes as per request

**in standard version CONTIN mode is available up to 600 A, but it can be available for 800 A (5 s) as per request

- Full Load Voltages at maximum current

Model	@ 230 V AC	@ 115 V AC
RMO100G	7,15 V	6,80 V
RMO200G	6,80 V	5,90 V
RMO300G	6,00 V	4,80 V
RMO400G	6,70 V	4,40 V
RMO500G	5,95 V	5,10 V
RMO600G	5,90 V	3,80 V
RMO800G	4,70 V	2,85 V

Measurement

- Resistance range:
0 Ω* – 999,9 mΩ* for RMO100 – 600G,
**expandable from 0 Ω up to 6 Ω*
0,1 μΩ – 499,9 mΩ for RMO800G
- Resolution

0 Ω – 999,9 μΩ	0,1 μΩ
1,000 mΩ – 9,999 mΩ	1 μΩ
10,00 mΩ – 99,99 mΩ	10 μΩ
100,0 mΩ – 999,9 mΩ	0,1 mΩ
*1,000 Ω – 6,000 Ω	1 mΩ
- Typical accuracy ± (0,1 % rdg + 0,1 % FS)

Display

- LCD screen 20 characters by 4 lines;
- LCD display with backlight, visible in bright sunlight.

Interface

- RMO-G is equipped with an USB port
- optional: RS232 (connection to an external computer)
- optional: Bluetooth communication interface

Test Result Storage

- RMO-G can store up to 500 measurements

Printer (optional)

- Thermal printer
- Paper width 80 mm / 3.2 in

Dimensions and weight

Model	Weight kg / lbs	Dimensions (W x H x D) mm / in
RMO100G	8 kg / 17.6 lbs	405 x 165 x 330 mm 7.8 x 10 x 15 in
RMO200G	8 kg / 17.6 lbs	
RMO300G	8 kg / 17.6 lbs	*RMO100G/200G/300G/400G/500G in version without built-in thermal printer
RMO400G	9 kg / 20 lbs	
RMO500G	9 kg / 20 lbs	480 x 190 x 385 mm 18.9 x 7.48 x 15.16 in
RMO600G	11 kg / 24.3 lbs	
RMO800G	11,5 kg / 25.4 lbs	*RMO600G/RMO800G and all RMO-Gs in version with built-in thermal printer

Environmental protection

- Ingress protection rating: IP67*with closed lid

Environmental conditions

- Operating temperature:
-20 °C - +55 °C / -4 °F - +131 °F
- Storage & transportation:
-40 °C - +70 °C / -40 °F - +158 °F
- Humidity 5 % - 95 % relative humidity

Applicable Standards

- Installation/overvoltage: category II
- Pollution: degree 2
- Safety: LVD 1006/95/EC (CE Conform) EN 61010-1
- EMC: Directive 1004/108/EC (CE Conform) Standard EN 61326-1:1006
- CAN/CSA-C22.2 No.61010-1, 2nd edition, including Amendment 1

Warranty

- 3 Years

All specifications herein are valid at ambient temperature of + 25 °C and recommended accessories. Specifications are subject to change without notice.

Accessories



Current cables



Extension current cables



Voltage sense cables



Current clamp 30/300A power supplied from the instrument with extension 5 m



Test shunt



Cable bag

* Besides battery clamps, current cables are also available with C clamps or with alligator clamps (as option)

** Besides isolated alligator (A2) clamps, sense cables are also available with semi-isolated alligator (A1) clamps or with TTA clamps (as option)

Recommended cross-sections for RMO-G models:

CROSS SECTION/ LENGHT	16 mm ²	25 mm ²	35 mm ²	*50 mm ²	*70 mm ²	*95 mm ²
5 m	RMO100G	RMO200G	RMO300G & RMO400G	RMO500G & RMO600G	-	*RMO800G
10 m	RMO100G	RMO200G	RMO300G & RMO400G	RMO500G & RMO600G	-	*RMO800G
15 m	-	RMO100G	RMO200G	RMO300G & RMO400G	RMO500G & RMO600G	-

*RMO800G device can use cables with 50, 70 or 95 mm² cross-section, depending of the required resistance measurement range at 800 A test current.

Order info

Instrument with included accessories	Article No
Micro Ohmmeter RMO-G <ul style="list-style-type: none"> - DV-Win PC software including USB cable - Mains power cable - Ground (PE) cable 	RMO100G-N-00 RMO200G-N-00 RMO300G-N-00 RMO400G-N-00 RMO500G-N-00 RMO600G-N-00 RMO800G-N-00
Recommended accessories	Article No
Current cables 2 x 5 m, *XX mm ² with battery clips	C2-05-XXYMBY**
Sense cables 2 x 5 m with alligator clips	S2-05-02BPA2
Transport case *RMO100G/200G/300G/400G/500G in version without built-in thermal printer	HARD-CASE-SC
Cable bag	CABLE-BAG-00
Optional accessories	Article No
Transport case *RMO100G/200G/300G/400G/500G in version without built-in thermal printer	HARD-CASE-SC
Transport case *RMO600G/RMO800G and all RMO-Gs in version with built-in thermal printer	HARD-CASE-LC
Cable plastic case – medium size	CABLE-CAS-02
Test shunt 100 μΩ (600 A/60 mV)	SHUNT-600-MK
Current cables 2 x 10 m, *XX mm ² with battery clips	C2-10-XXYMBY**
Current cables 2 x 15 m, *XX mm ² with battery clips	C2-15-XXYMBY**
Current extension cable 2 x 10 m, *XX mm ²	E2-10-XXYMYF
Sense cables, extension 2 x 10 m	E2-10-02BPBP
Sense cables 2 x 10 m with alligator clips	S2-10-02BPA2
Sense cables 2 x 15 m with alligator clips	S2-15-02BPA2
Built-in thermal printer	PRINT-080-00
High Precision Module (built-in)	RMO-HPMM-DG0
Remote control unit	RMORCU-09-00
Remote control test probes (one with trig button)	RMO-RCTP-TB0
Current clamp 30/300 A power supplied from the instrument with extension 5 m (Both Sides Grounded Unit)	CACL-0300-06

*XX - Cross-section of current cables varies, depending of the output power of the model.

**YMBY – For RMO100G and RMO200G without built-in thermal printer: YMBY=LMB1;

For RMO100G and RMO200G with built-in thermal printer and for other models: YMBY=VMB3

e.g.

For RMO200G without built-in thermal printer, the article number for current cables 10 m/25 mm² cross-section is C2-10-25LMB1

For RMO600G, the article number for current cables 5m/50 mm² is C2-05-50VMB3